

Smartio C168H/PCI User's Manual

8 Port Serial Board for PCI Bus

Fourth Edition June 2008

This manual is also available on CD-ROM and at the Moxa web site.



© 2008 Moxa Inc., all rights reserved.
Reproduction without permission is prohibited.

Smartio C168H/PCI User's Manual

The software described in this manual is furnished under a license agreement and may be used only in accordance with the terms of that agreement.

Copyright Notice

Copyright © 2008 Moxa Inc.

All rights reserved.

Reproduction without permission is prohibited.

Trademarks

MOXA is a registered trademark of Moxa Inc.

All other trademarks or registered marks in this manual belong to their respective manufacturers.

Disclaimer

Information in this document is subject to change without notice and does not represent a commitment on the part of Moxa.

Moxa provides this document “as is,” without warranty of any kind, either expressed or implied, including, but not limited to, its particular purpose. Moxa reserves the right to make improvements and/or changes to this manual, or to the products and/or the programs described in this manual, at any time.

Information provided in this manual is intended to be accurate and reliable. However, Moxa assumes no responsibility for its use, or for any infringements on the rights of third parties that may result from its use.

This product might include unintentional technical or typographical errors. Changes are periodically made to the information herein to correct such errors, and these changes are incorporated into new editions of the publication.

Technical Support Contact Information

www.moxa.com/support

Moxa Americas:

Toll-free: 1-888-669-2872

Tel: +1-714-528-6777

Fax: +1-714-528-6778

Moxa China (Shanghai office):

Toll-free: 800-820-5036

Tel: +86-21-5258-9955

Fax: +86-10-6872-3958

Moxa Europe:

Tel: +49-89-3 70 03 99-0

Fax: +49-89-3 70 03 99-99

Moxa Asia-Pacific:

Tel: +886-2-8919-1230

Fax: +886-2-8919-1231

Moxa Internet Services

Customer satisfaction is one of our number one concerns. To ensure that customers receive the full benefit of our products, Moxa Internet Services has been set up to provide technical support, driver updates, product information, and user's manual updates.

The following services are provided

E-mail for technical support: support@moxa.com.tw

FTP site for free driver updates: <ftp://ftp.moxa.com> or

..... <ftp://ftp.moxa.com.tw>

user ID: *ftp*

password: your_email_address

World Wide Website for product information:

..... www.moxa.com or

..... www.moxa.com.tw

About This Manual

This manual comprises six chapters and one appendix, and is written for the installer, system administrator, and software programmer.

If you are a first-time installer and system administrator, we recommend that you read the everything except chapter 4, *Serial Programming Tools*.

If you are a software programmer, refer to chapter 4, *Serial Programming Tools*.

If you need cable wiring information, see chapter 5, *Connection Option (Opt8x) and Cable Wiring*.

If you encounter installation problems, refer to chapter 6, *Troubleshooting*.

Chapter 1 Introduction

This chapter gives an overview, features, package check-list, and overall installation guide for C168H/PCI.

Chapter 2 Hardware Installation

Details the hardware installation procedure for C168H/PCI, and discusses the Opt8x connection option.

Chapter 3 Software Installation

Describes the software installation procedure, board and port configuration, as well as driver updating and removal for Windows NT/95/98 operating systems.

Chapter 4 Serial Programming Tools

Gives a rough description of the programming tools for various OS platforms, including *PComm Lite* under Windows NT/95/98. The Opt8J RS-485 programming issue is also discussed.

Chapter 5 Connection Option (Opt8x) and Cable Wiring

This chapter describes RS-232/422/485 cable wiring for each connection option (Opt8x).

Chapter 6 Troubleshooting

Discusses problems that could arise when using C168H/PCI, and solutions to overcome the problems.

Appendix Technical Reference

This chapter describes specifications, PCI, UART, and DB62 pinouts.

Table of Contents

Introduction	1-1
Overview-----	1-1
Features-----	1-2
Checklist-----	1-3
Installation Guide-----	1-5
Hardware Installation	2-1
Installing the Smartio C168H/PCI Board-----	2-1
Installing Connection Option Opt8x-----	2-2
Software Installation.....	3-1
Windows NT-----	3-1
Installing the Driver-----	3-2
Configuring Board and Port-----	3-12
Updating the Driver-----	3-17
Removing the Driver-----	3-17
Windows 95/98-----	3-18
Installing a Driver-----	3-19
Configuring Board and Port-----	3-27
Updating the Driver-----	3-29
Removing the driver-----	3-31
Serial Programming Tools	4-1
<i>PComm</i> Installation-----	4-1
<i>PComm</i> Programming Library-----	4-2
Utility-----	4-2
RS-485 Programming for Opt8J-----	4-6
Connection Option (Opt8x) & Cable Wiring	5-1
RS-232 Cable Wiring for Opt8A/B/C/D/S-----	5-1
RS-422 Cable Wiring for Opt8J/F/Z-----	5-9
RS-485 Cable Wiring for Opt8J-----	5-11
RS-422/485 Impedance Matching-----	5-12
Troubleshooting	6-1
General Troubleshooting-----	6-1
Windows NT-----	6-2
Windows 95/98-----	6-3

Technical Reference.....	1
Specifications-----	1
PCI-----	1
UART 16C550C-----	2
DB62 Connector Pinouts-----	3

Overview

Smartio—Smart Multiport Async Solutions

Smartio products represent smart, multiport, serial I/O solutions for the modern technological world. Smartio C168H/PCI is designed for a 32-bit PCI bus with the plug-and-play feature. It offers 8 serial ports for connecting terminals, modems, printers, data acquisition equipment, and other serial devices to a PC. Smartio C168H/PCI is a well-designed, fine-tuned device driver, and as such makes full use of the 32 byte Tx/Rx FIFO and on-chip H/W flow control, making it possible to transfer data, without loss, at speeds up to 921.6 Kbps. This product offers a reliable and high performance solution for serial multiport communications.

Board Applications

The Smartio C168H/PCI board can be used for many applications. Here are just a few:

- Internet/Intranet Connection
- Remote Access Applications
- Multi-User Applications
- Industrial Automation
- Office Automation
- Telecommunications
- PC-based (vending) Machine or Kiosk System
- POS (Point-Of-Sale) System

PCI Solution

The Smartio C168H/PCI board complies with PCI Spec. 2.1, and since the hardware configuration for IRQ and memory addresses is done automatically by the PCI BIOS, it does not require either switches or jumpers. This means that the board must be plugged in first before installing the driver software. For more PCI information, refer to the *Technical Reference* appendix.

Operating System Support

Smartio C168H/PCI supports Windows NT, Windows 95/98, and DOS, with user-friendly installation, configuration, and performance.

Moxa Serial Comm Tool

Moxa *PComm* is an easy-to-use serial communication library that runs under Windows NT and Windows 95/98. The library comes with sample applications developed with compilers such as Visual Basic, Visual C++, and Borland Delphi. It contains the useful diagnostic, monitor, and terminal emulation utilities, making it easy to develop your own applications. Furthermore, you can debug and monitor communication status, terminal emulation, and even file transfers.

Features

- ❖ Compact board size (half-size)
- ❖ Plug and play, no switches or jumpers
- ❖ Surge/isolation protection option
- ❖ High speed 16C550C Communication Controller with on-chip hardware flow control; no data loss, even at high transmission speeds
- ❖ Windows NT/95/98 device drivers and *PComm* serial comm tool
- ❖ Bus interface: 32-bit PCI
- ❖ Number of ports: 8
- ❖ I/O address: assigned by PCI BIOS
- ❖ IRQ: assigned by PCI BIOS
- ❖ Data bits: 5, 6, 7, 8
- ❖ Stop bits: 1, 1.5, 2
- ❖ Parity: none, even, odd, space, mark
- ❖ UART: 8 × 16C550C or compatible
- ❖ Speed: 50 – 921.6 Kbps
- ❖ Connectors: 8 × DB25/DB9, male or female
- ❖ Data signals: RS-232 – TxD, RxD, RTS, CTS, DTR, DSR, DCD, GND

RS-422 – TxD+(B), TxD-(A), RxD+(B), RxD-(A), GND
(Opt8J:RTS+(B), RTS-(A), CTS+(B), CTS-(A))

RS-485 – Data+(B), Data-(A), GND

- ❖ Operating temp: 0 – 55 °C
- ❖ Power requirement: 180 mA max. (+5V)
110 mA max. (+12V)
160 mA max. (-12V)
- ❖ Dimensions: 123 × 100 cm
- ❖ Popular OS supported:

	C168H/PCI
Windows NT	✓
Windows 95/98	✓
Dos	R

—: Driver supported by Moxa and shipped with product

R: Driver supported by Moxa and shipped by request

Note: You can download the latest driver versions for the above OS from the Moxa FTP service. Drivers for other OS may also be available. Check the Moxa web site for complete information.

Checklist

Smartio C168H/PCI is shipped with the following items:

- ❖ Smartio C168H/PCI 8 port serial board
- ❖ Software CD containing:
 - Windows NT and Windows 95/98 device drivers
 - *PComm Lite*
- ❖ This User's Manual
- ❖ One of the following connection options:

Opt8A/Opt8B/Opt8S

- ❖ RS-232 connection box with 8 DB25 female/male ports (surge protection for Opt8S).
- ❖ 1.5 meter DB62 to DB62 cable.

Opt8C/Opt8D

- ❖ RS-232 octopus cable with 8 male DB25 port connectors, for Opt8C or DB9 for Opt8D (1 meter long).

Opt8F/Opt8Z

- ❖ RS-422 connection box with 8 female DB25 port connectors (isolation protection for Opt8F).
- ❖ 1.5 meter DB62 to DB62 cable.
- ❖ 110V or 220V adapter included.

Opt8J

- ❖ RS-422/485 connection box with 8 female DB25 port connectors.
- ❖ 1.5 meter DB62 to DB62 cable.
- ❖ 110V or 220V adapter included.

Installation Guide

This section gives a brief summary of how to install Smartio C168H/PCI for each supported operating system. Installation is simple and involves the following stages:

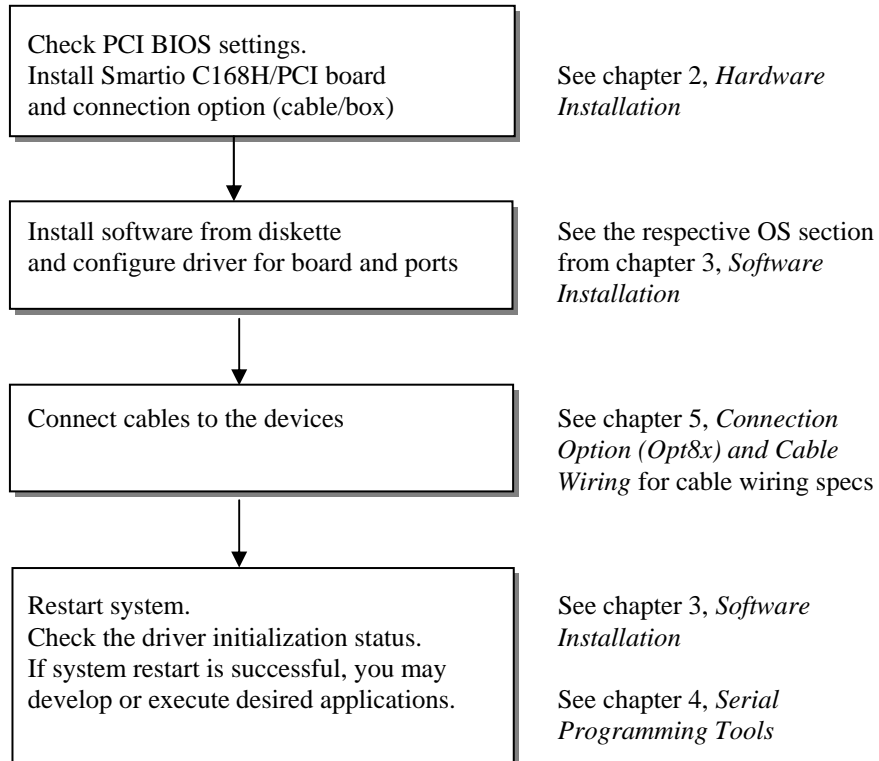

2

Hardware Installation

Installing Smartio C168H/PCI consists of both hardware and software installation. This chapter describes how to install the hardware, and in the next chapter, we discuss software installation.

The no-switch/no-jumper Smartio C168H/PCI board hardware configuration is straightforward, since the IRQ number and I/O addresses are automatically assigned by the PCI BIOS. This means that the board **MUST** be plugged in before installing the driver software.

Installing the Smartio C168H/PCI Board

Step 1: Turn off the PC and disconnect the power cable.

Warning! Make sure your system is turned off before installing an expansion board. If you do not first shut down the computer, you risk damaging both the PC and the board.

Step 2: Remove the PC cover.

Step 3: Remove the slot cover bracket if there is one.

Step 4: Plug the Smartio C168H/PCI(s) into the PC's free PCI expansion slot(s).

Step 5: Fasten the holding screw to fix the control board in place.

Step 6: Replace the system cover.

Step 7: Connect one of the connection boxes/cables (and adapter if required) detailed in the next section.

Step 8: Turn on your PC. The BIOS will automatically assign the IRQ and memory address.

Note !

Each board must occupy one unique IRQ and one unique memory address, assigned automatically by the PCI BIOS. You may, however, use the PC's PCI-slot BIOS setup to manually assign a free IRQ number. This method, however, is usually not available to assign the memory address. The IRQ numbers that can be used are 2, 3, 4, 5, 9, 10, 11, 12, and 15. The I/O addresses that can be used range from 0x0000 to 0xFFFF.

Step 9: Proceed with the software installation, detailed in the next chapter, *Software Installation*.

Installing Connection Option Opt8x

Use one of the following connection options to set up your Smartio C168H/PCI. After that, connect your modem, serial printer, PC COM1/2, bar code reader, POS device, instrument, or any other serial device to the board's DB25/DB9 connectors. Refer to the chapter *Connection Option (Opt8x) and Cable Wiring* for RS-232/422/485 cable wiring specs.

Opt8A/Opt8B/Opt8S

Plug one end of the DB62 cable into Smartio C168H/PCI's DB62 bracket connector, and then carefully tighten the attachment screws. After that, plug the other end of the cable into the RS-232 connection box's DB62 connector. Note that both ends of the cable are identical.

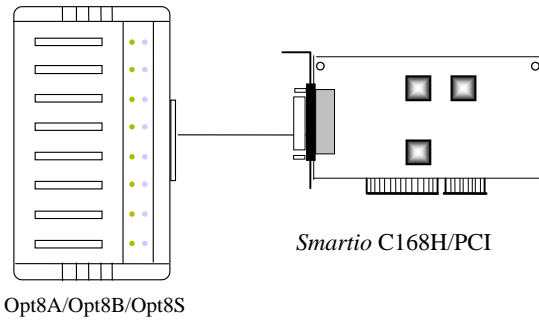

Opt8C/Opt8D

Plug one end of the DB62 cable into Smartio C168H/PCI's DB62 bracket connector, and then carefully tighten the attachment screws.

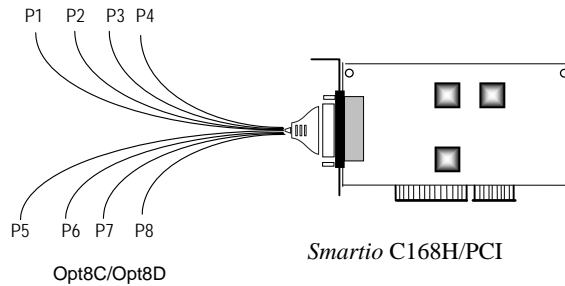

Opt8J/Opt8F/Opt8Z

Plug one end of the DB62 cable into Smartio C168H/PCI's DB62 bracket connector, and then carefully tighten the attachment screws. After that, plug the other end of the cable into the RS-232 connection box's DB62 connector. Note that both ends of the cable are identical. Don't forget to attach the Opt8J/F/Z's power adapter.

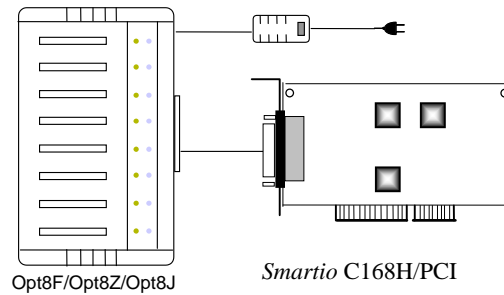

Refer to the chapter *Connection Option (Opt8x) and Cable Wiring* for RS-232/422/485 cable wiring, and refer to the chapter *Serial Programming Tools* for RS-232/422/485 programming details.

Operating Opt8J

Opt8J is an RS-422/485 connection box that is used with Moxa's 8-port boards, including Smartio C168H/PCI. It has 8 female DB25 port connections, and 8 DIP switches on the side, with each switch used to set the communication mode (RS-422 or RS-485) of one port.

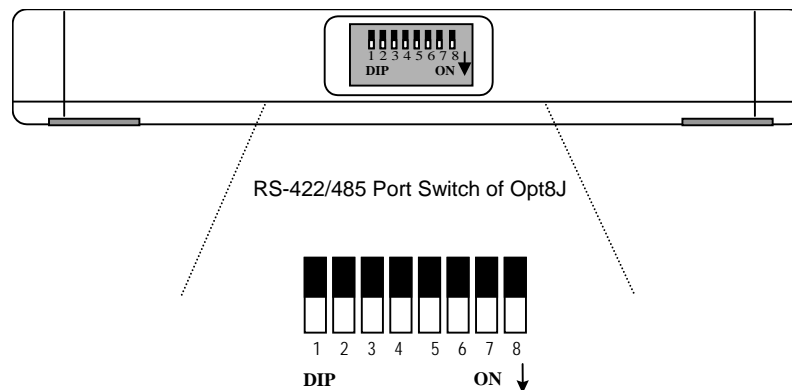

RS-422 Mode

Set the DIP switch to the **OFF** position to use the RS-422 interface. This means that the port is set to full-duplex; i.e., it is always ready to simultaneously transmit and receive data.

RS-485 Mode

Set the DIP switch to the **ON** position to use 2-wire RS-485 communication. This means that the port is set to half-duplex; i.e., it can transmit data only when RTS is asserted, and can receive data only when RTS is not asserted.

Refer to the chapter *Connection Option (Opt8x) and Cable Wiring* for RS-422/485 cable wiring specs, and to the chapter *Serial Programming Tools* for Opt8J RS-485 programming details.

3

Software Installation

In this chapter, we describe driver installation and configuration, and driver update and removal procedures for Windows NT/95/98. You must first complete the hardware installation before proceeding with the software installation.

If you wish to develop your own applications, please refer to the next chapter, *Serial Programming Tools*, for a discussion of serial programming issues.

Windows NT

Windows NT can support up to 256 serial ports, from COM1 to COM256. To fully utilize Windows NT's advanced multi-process and multi-thread features, Moxa has developed pure, 32-bit device drivers for Smartio C168H/PCI, and other Moxa multiport boards. These drivers all conform to the Win32 COMM API standard.

Go directly to the section *Installing the Driver* to install the driver for the first time.

Refer to the section *Configuring Board and Port* to learn how to re-configure a board that is already installed.

Refer to the section *Updating the Driver* for information on how to update the driver for a board that is already installed.

Refer to the section *Removing the Driver* to see how to delete a driver from your system.

Installing the Driver

The key step in installing the Windows NT driver for your Moxa Smartio C168H/PCI board is the **Moxa Smartio/Industio Configuration Panel**, shown below. You will either click on **Add**, **Remove**, or **Property**, depending on whether you are installing the driver for the first time, removing the driver, or simply updating the configuration.

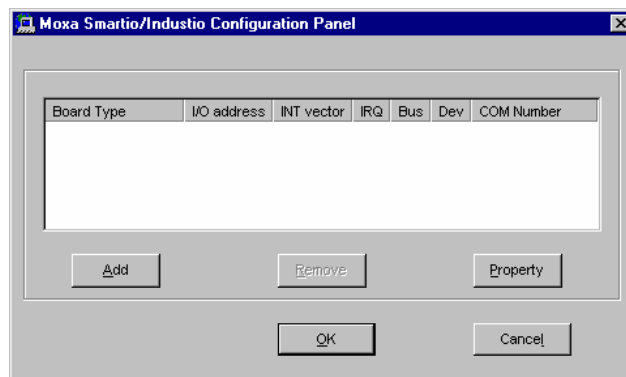

- If you are installing a board for the first time, or you are installing an additional board, you will use the **Add** button.
- If you would like to remove a board, you will use the **Remove** button.
- To update the configuration properties of a particular board, you will use the **Property** button.

The following sections contain details of how to add, configure, and remove a driver.

First Time Installation

In this section we give the procedure you should follow to install the Smartio C168H/PCI driver for the first time under Windows NT 3.51/4.0. To begin with, make sure that all of the boards have been properly plugged into your system's PCI slots, as described in the previous chapter.

1. Log onto your NT system as the administrator.
2. From the Windows NT desktop, click on **Start → Control Panel** to open the Control Panel.

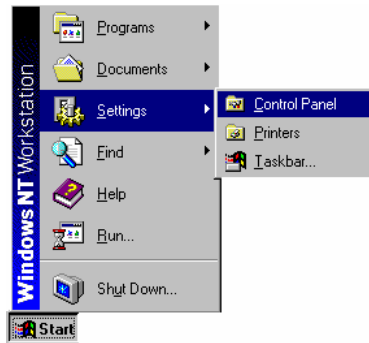

3. Click on the **Network** icon (shown highlighted in the figure below) in the **Control Panel** window.

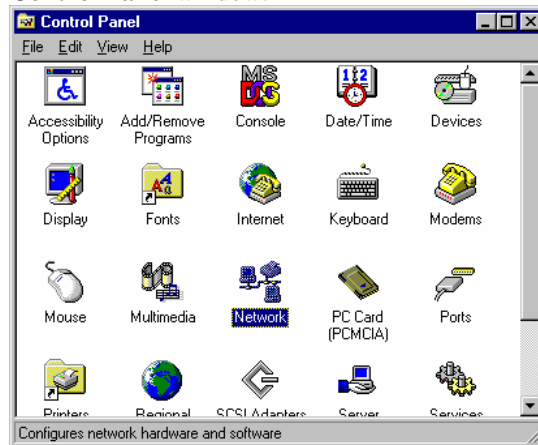

4. Click on the **Adapters** tab, and then click the **Add** button.

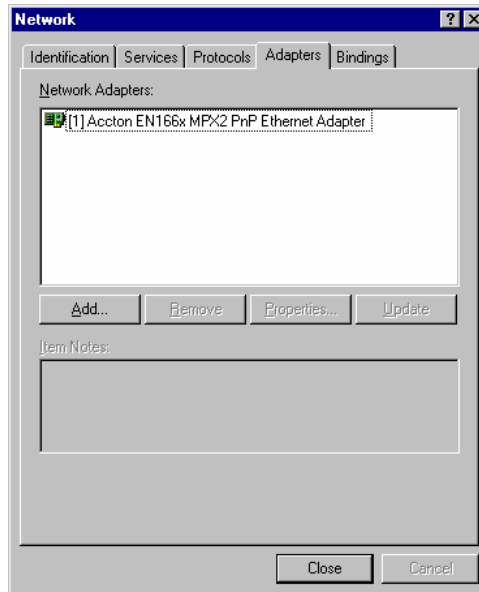

5. Click on **Have Disk...** in the **Select Network Adapter** window.

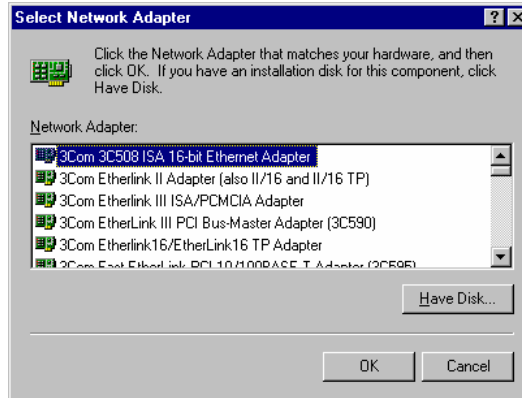

6. Specify the exact path of the driver disk, `G:\Windows.nt` for the example shown below (use a different drive letter—A, B, C, etc.—if the disk is located in a different drive), and then click **OK** to continue.

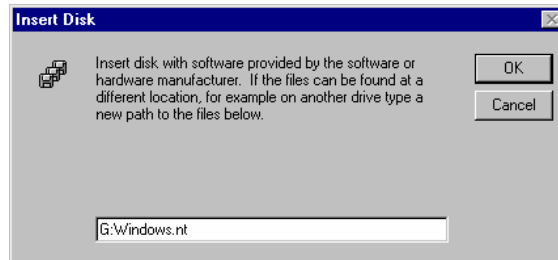

7. Click on **Moxa Smartio/Industio Family multiport board** from the **Select OEM Option** window to highlight it, and then click **OK** to begin installing the driver.

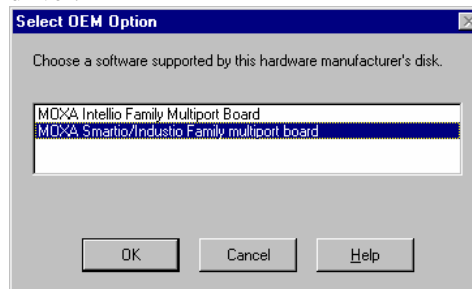

8. The **Setup** window will appear briefly to indicate that program files are being copied to the specified directory.

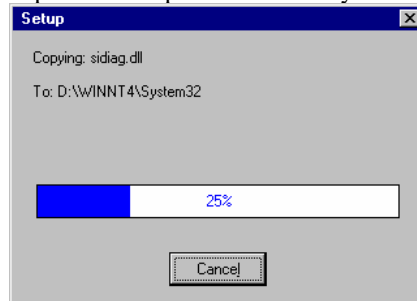

9. The **Moxa Smartio/Industio Configuration Panel** window appears. Click the **Add** button to open the **Property** info box to change port settings and advanced FIFO configurations.

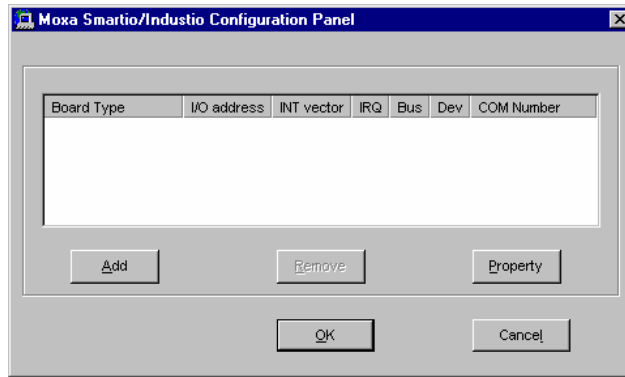

10. Select **C168 PCI Series** board from the **Board Type** pull-down list. Click on a specific port in the **Port** info-box, and then click on **Port Setting** to open the **Port X** properties window.

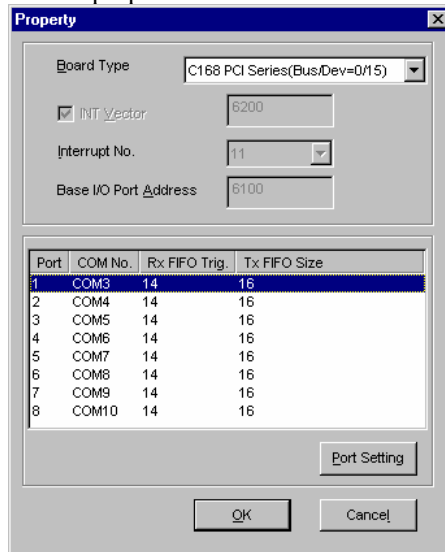

Note: Step 11 is optional if you wish to manually assign COM numbers to ports.

11. Select a COM number for the port from the **Port Number** pull-down list.

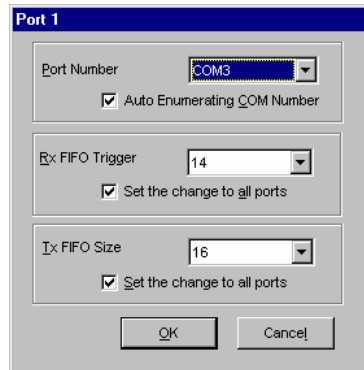

12. Check the **Auto Enumerating COM Number** checkbox to have subsequent ports mapped to consecutive COM numbers. For example, if COM3 is assigned to Port 1, then COM4 will be automatically assigned to Port 2, etc.



Note: You may skip steps 13 and 14 if the system does not require special performance tuning.

13. Select an Rx FIFO Trigger from the **Rx FIFO Trigger** pull-down list.

Check the **Set the change to all ports** checkbox if you want to apply this Rx FIFO Trigger to every port.

14. Select a Tx FIFO Size from the **Tx FIFO** size pull-down list.

Check the **Set the change to all ports** checkbox if you want to apply this Tx FIFO Size to all ports.

15. Click **OK** in the **Port X** window to confirm the port settings and return to the **Property** window. Click **OK** to complete the port settings.

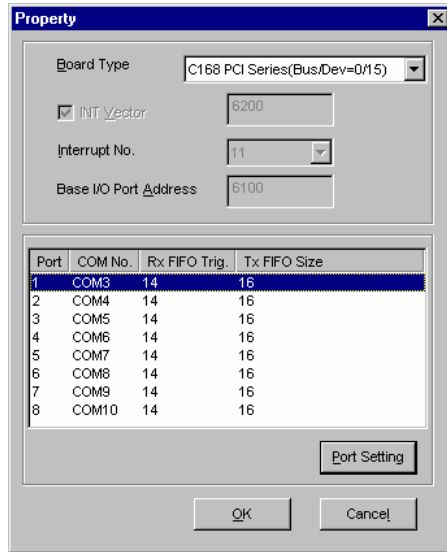

16. The **Moxa Smartio/Industio Configuration Panel** window reopens, indicating that the Smartio C168H/PCI board has been successfully installed. Click **OK** to continue.

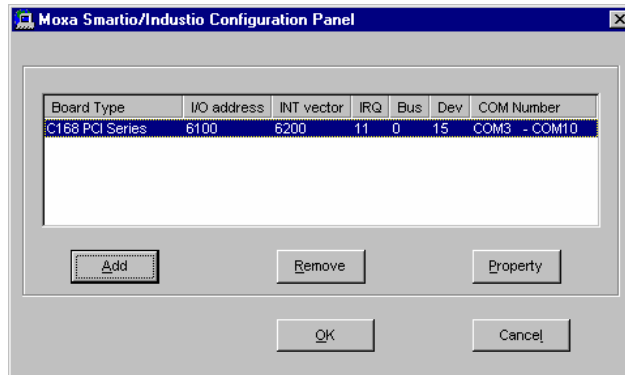

17. The **Network** window **Adapters** page opens, with the newly installed Moxa board listed. Click on **Close** to close the window.

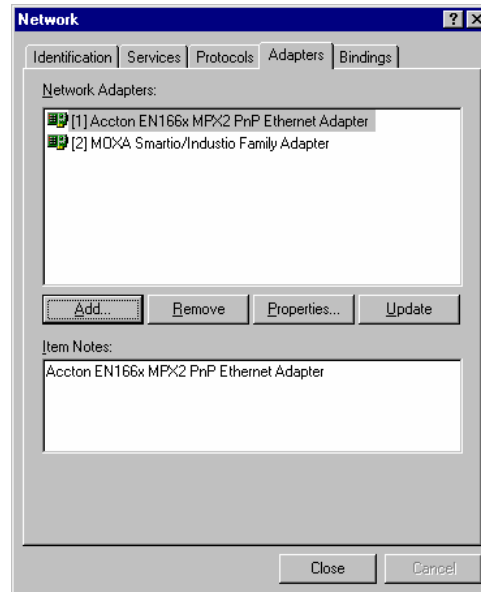

18. Windows NT will run through some basic procedures, after which you will be prompted to restart the system. Click on **Yes** to restart the computer at this time.

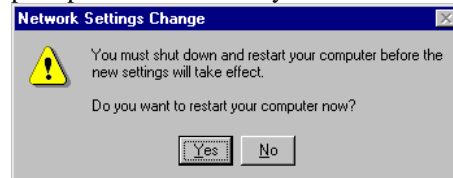

*Note: The driver configuration will **NOT** take effect until you restart the PC.*

Once the system restarts, you can check the event log issued by the Moxa driver to see if the ports on the board were initialized successfully.

1. From the Windows NT desktop click on **Start → Programs → Administrative Tools (Common) → Event Viewer** to open the Event

Viewer window.

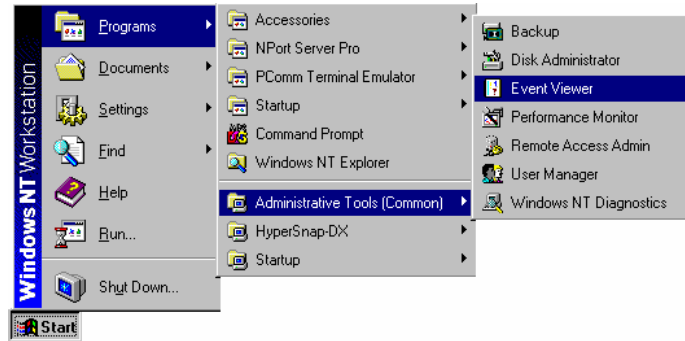

2. Locate and then highlight the **Mxserp** line, as shown below, and then press **Enter**.

The image shows a screenshot of the Event Viewer window titled 'Event Viewer - System Log on \\MOXATIM'. The window has a menu bar with 'Log', 'View', 'Options', and 'Help'. Below the menu bar is a table of events. The table has five columns: 'Date', 'Time', 'Source', 'Category', and 'Event'. The event with 'Source' 'Mxserp' and 'Event' '49' is highlighted in blue.

Date	Time	Source	Category	Event
9/14/00	5:29:50 PM	Service Control Mar	None	7026
9/14/00	5:29:04 PM	NPort	None	16
9/14/00	5:29:04 PM	NPort	None	7
9/14/00	5:29:04 PM	NPlit	None	16
9/14/00	5:29:04 PM	NPlit	None	7
9/14/00	5:28:51 PM	EventLog	None	6005
9/14/00	5:29:04 PM	Mxserp	None	49
9/14/00	5:27:22 PM	BROWSER	None	8033
9/14/00	5:27:18 PM	BROWSER	None	8033
9/14/00	5:27:17 PM	BROWSER	None	8033
9/14/00	5:14:37 PM	Service Control Mar	None	7026
9/14/00	5:13:40 PM	NPort	None	16
9/14/00	5:13:40 PM	NPort	None	7
9/14/00	5:13:40 PM	NPlit	None	16
9/14/00	5:13:29 PM	EventLog	None	6005
9/14/00	5:13:40 PM	NPlit	None	7

3. The **Event Detail** window opens, indicating that the Moxa C168 PCI series board has been enabled. Click on **Close** to close the window.

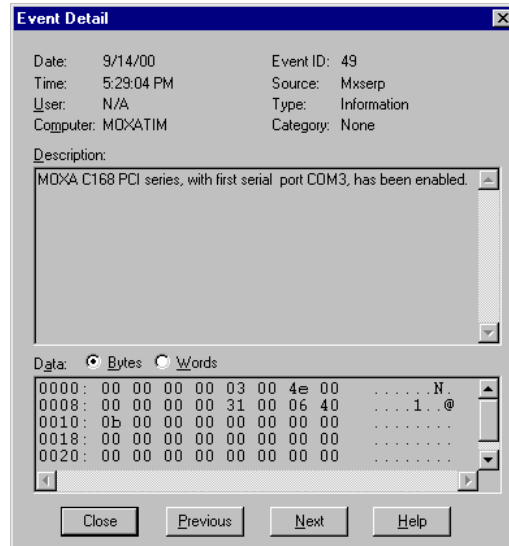

*Note: If an error message similar to **Cannot find any configured Moxa Smartio/Industio series board!** pops up, see the Troubleshooting chapter for solutions.*

You can start developing applications with the *PComm* library (see *Serial Programming Tools*) or Microsoft Win32 API, once the board and driver have been installed and the system has restarted successfully. You may also execute ready-made applications, such as the *PComm* utility Terminal Emulator (see *Serial Programming Tools*) or HyperTerminal, to transmit/receive data, as well as Remote Access Service, to provide dial-up networking capabilities.

Configuring Board and Port

Re-Configuring Port Settings

If the driver is already installed and you only need to re-configure the ports, either click on **Start → Program Files → Moxa Utility → Moxa Smartio/Industio Configuration Panel → Property**, or follow steps 1–5 listed below, and then refer to steps 11–18 from the previous subsection.

1. From the Windows NT desktop, click on **Start → Control Panel** to open the Control Panel.

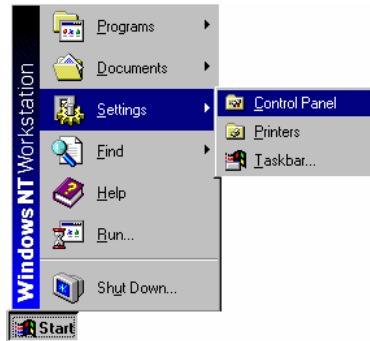

2. Click on the **Network** icon (shown highlighted in the figure below).

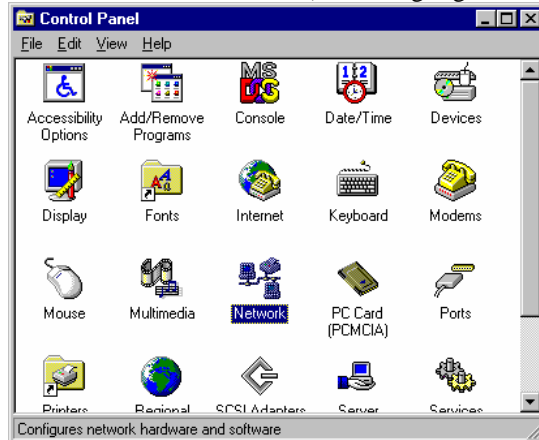

3. Select **Moxa Smartio/Industio Family Adapter** from the list on the **Adapters** page, and then click on **Properties...**

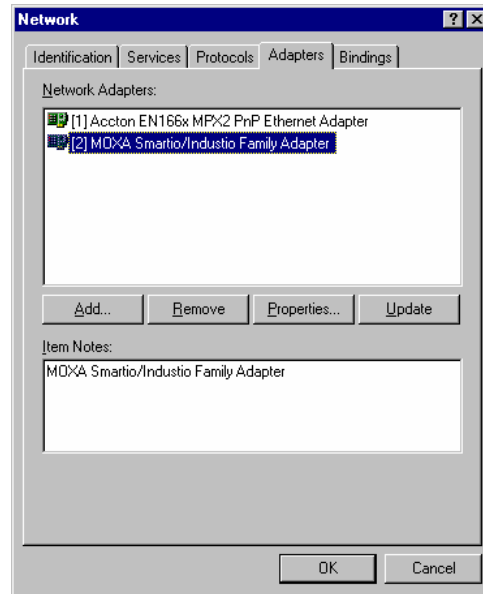

4. Click on **Property** to continue.

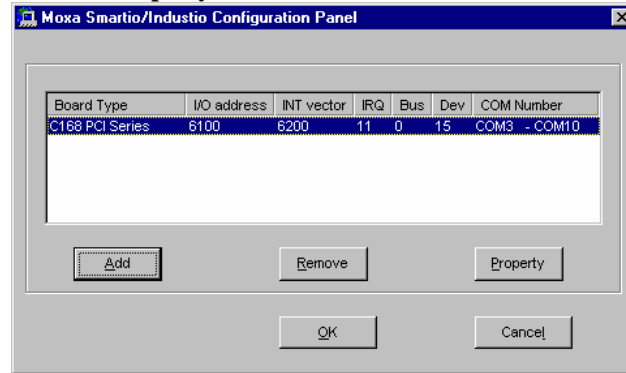

5. Once the **Property** window opens, follow steps 11 to 18 from the previous section to change the configuration settings.

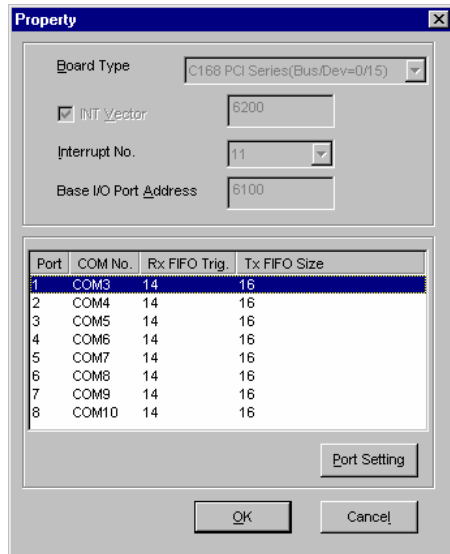

Configuring Another C168H/PCI Board

Read this section if you are installing another Moxa C168H/PCI board. As long as the Windows NT system has sufficient resources, up to four C168H/PCI boards can be installed on one system.

To proceed, either click on **Start → Program Files → Moxa Utility → Moxa Smartio/Industio Configuration Panel → Property**, or follow steps 1–5 listed below, and then refer to steps 11–18 from the previous section.

1. From the Windows NT desktop, click on **Start → Control Panel** to open the Control Panel.

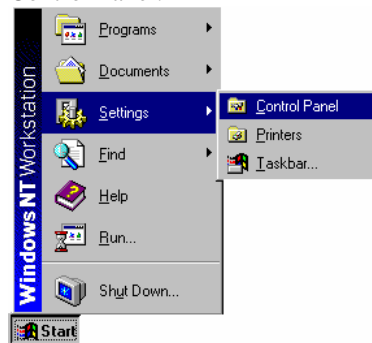

- Click on the **Network** icon (shown highlighted in the figure below).



- Select **Moxa Smartio/Industio Family Adapter** from the **Network Adapters** list, and then click on **Properties...**

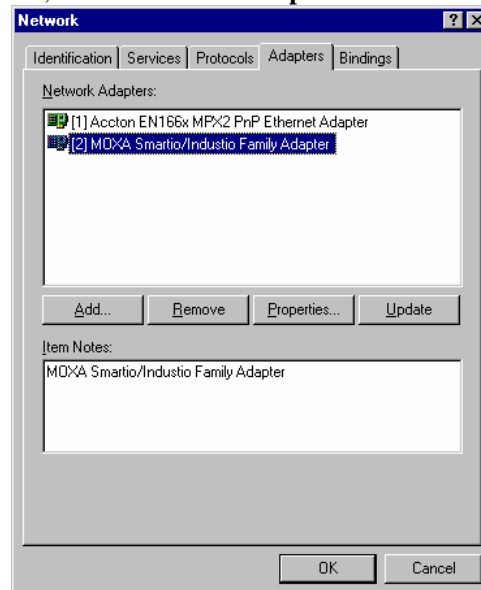

- The **Moxa Smartio/Industio Configuration Panel** opens. Click on **Property** to continue.

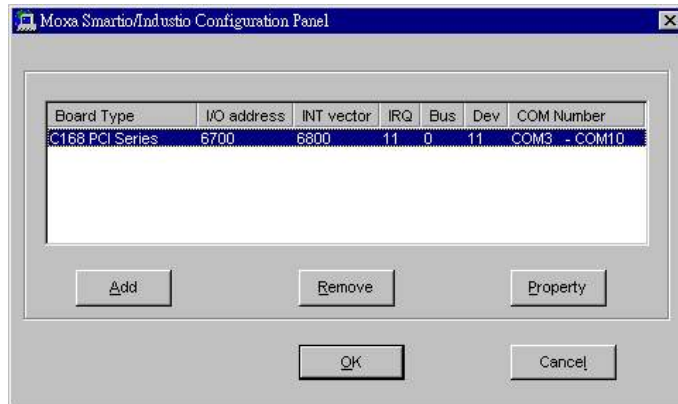

- The board's **Property** window opens.

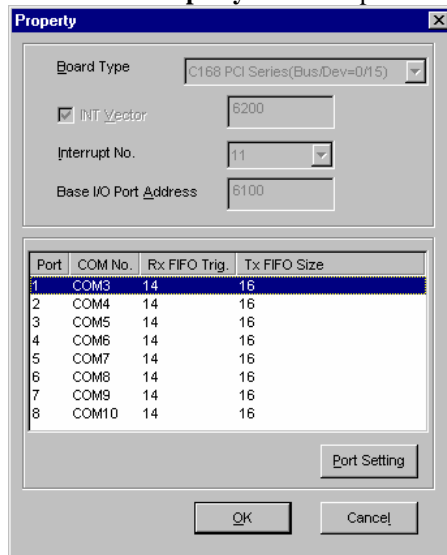

- Now refer to steps 10 – 18 in *First Time Installing Driver* from the *Windows NT* section.

Removing an Existing C168H/PCI Board Configuration

One option is to simply unplug the C168H/PCI board, while the computer is shut down. After restarting the computer, you will find that the configuration has been automatically removed. Alternatively, you could perform the removal from the **Moxa Smartio/Industio Configuration Panel** dialog box, by highlighting the

board to be removed, and then clicking on the **Remove** button.

Updating the Driver

To update the Smartio C168H/PCI driver you must first remove the exiting driver, and then install the new driver.

1. Open **Control Panel**, click on the **Network** icon, and then select the **Adapters** tab.
2. Choose **Moxa Smartio/Industio Family Adapter** from the **Network Adapters** list.
3. Click on **Remove** in the **Network** dialog box.
4. Click on **Close** in the **Network** dialog box.
5. Restart the system.
6. To install a new driver, refer to steps 1 to 21 in the subsection *First Time Installing Driver*, from the *Windows NT* section.

Removing the Driver

To remove the Smartio C168H/PCI board driver, you should:

1. Open **Control Panel**, click on the **Network** icon, and then select the **Adapters** tab.
2. Choose **Moxa Smartio/Industio Family Adapter** from the **Network Adapters** list.
3. Click on **Remove** in the **Network** dialog box.

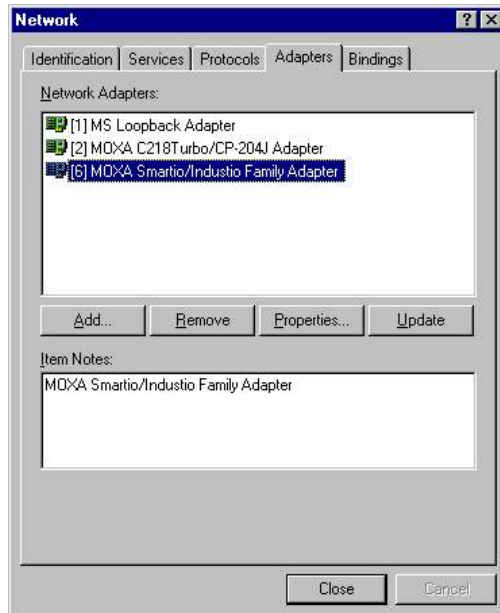

4. Click on **Close** to exit the **Network** dialog box.
5. Restart the system to activate the new configuration.

Windows 95/98

The Windows 95/98 driver supports up to 128 serial ports, from COM1 to COM128. To fully utilize Windows' advanced multi-process and multi-thread features, Moxa has developed pure, 32-bit virtual device port drivers (VxD), compliant with communication drivers (VCOMM), for the Smartio C168H/PCI and other Moxa multiport boards. All of these drivers conform to the Win32 COMM API standard.

Go directly to the section *Installing a Driver* for first time driver installation, or to add more boards.

To re-configure the ports for boards that are already installed, refer to the section *Configuring Board and Port*.

To update a driver, see the section *Updating the Driver*.

To remove a driver, go to the section *Removing the Driver*.

Installing the Driver

The **Plug and Play** feature supported by Windows 95/98 allows you to plug the Smartio C168H/PCI board into your PC, and then get to work almost immediately with very little installation effort. Windows 95/98 automatically detects the presence of the new board, and prompts you to install the driver software. You will need the driver diskette to do this.

A maximum of 4 Smartio C168H/PCI boards can be installed on one system, provided the system's I/O addresses and IRQ number resources are sufficient and available.

The following flow chart illustrates the driver installation stages for the Smartio C168H/PCI boards. Each stage of the procedure will be discussed in more detail later.

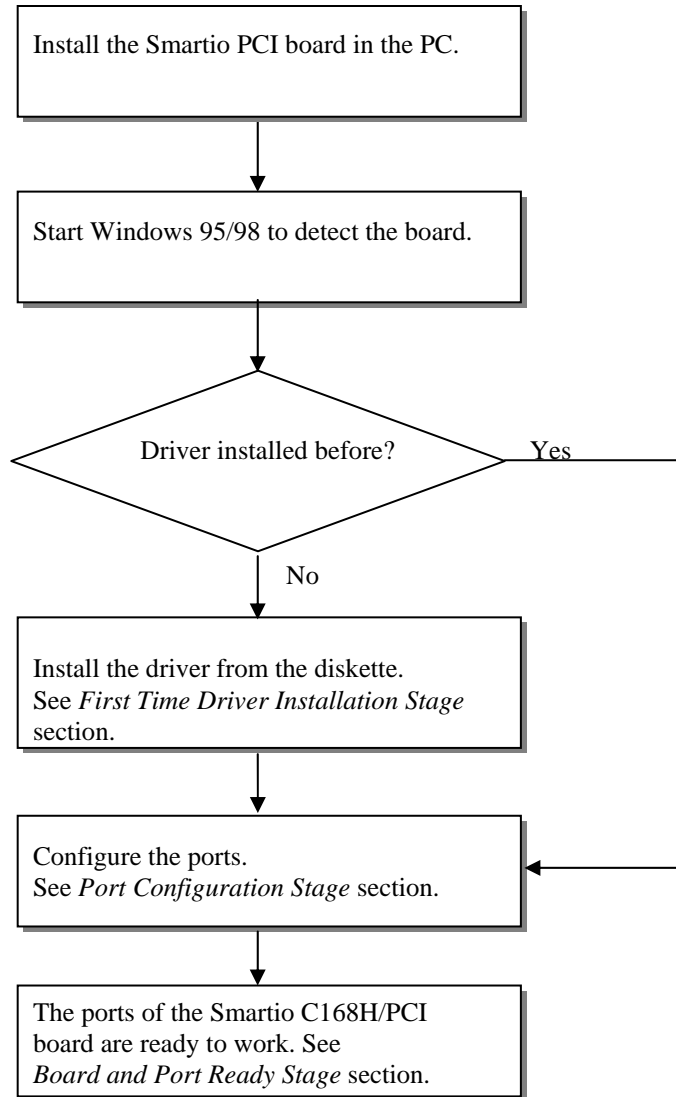

First Time Driver Installation Stage

This stage is relevant if you are adding the first Smartio C168H/PCI board to your PC, and are installing the driver for the first time. The installation of the Smartio C168H/PCI board for Windows 95 and Windows 98 is slightly different, and will be described in two separate columns. The left column is for Windows 95 and the right column for Windows 98.

If a Moxa C168H/PCI board has previously been installed and you are adding another board, the system will prompt you to skip to the **Port Configuration Stage** discussed in the next section.

1. Upon detecting the first new Smartio C168H/PCI board, Windows 95/98 will automatically display a **New hardware found** message box, after which the following dialog boxes will pop up. Click on **Next** to continue.

Windows 95



Windows 98



2. Click on **Other Locations**.



2. Select **Display a list...**, then click on **Next**.



3. In the **Select Other Location** window, type A:\Windows.95 in the **Location** text input box, and then click **OK**. This prompts the system to start copying the files from the diskette.

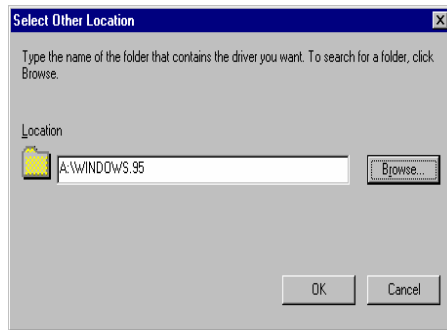

4. Click on **Finish**.



3. Select **Other Devices**, then click on **Next**.

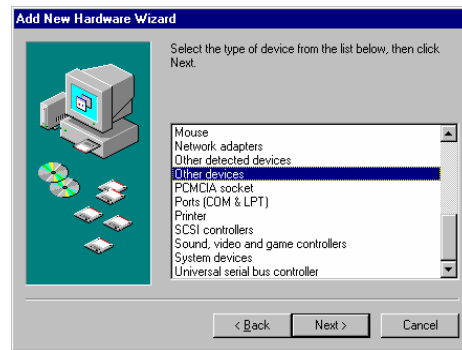

4. Click on **Have Disk**.



5. Type A:\Windows.95 and then click **OK**. This prompts the system to start copying the files from the diskette to your harddrive.



6. Click on **Next**.

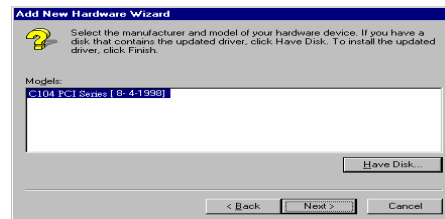

7. Click on **Next**.



Port Configuration Stage

After the driver has been installed, the **C168 PCI Series Installation** dialog box will be displayed, and the port mapping will be taken care of automatically by the system.

If one Moxa C168H/PCI board was previously installed, and you are adding another board to your system, you will be prompted to follow the port configuration instructions discussed in this section.

1. Click on a specific port.
2. Click on **Port Setting** to open the **Port X** dialog box.

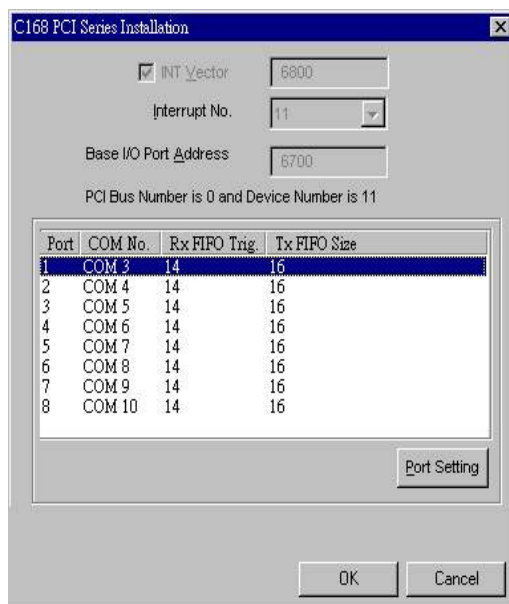

3. Select a COM number for the port from the **Port Number** pull-down list.

Note! Skip step 4 if you wish to manually assign COM numbers to your ports.

4. Click on the **Auto Enumerating COM Number** checkbox to have subsequent ports mapped to consecutive COM numbers. For example, if COM 3 is assigned to Port 1, then COM 4 will be automatically assigned to Port 2.

Note! Skip steps 5 to 8 if your system does not require special performance tuning.

5. Select an Rx FIFO Trigger from the **Rx FIFO Trigger** pull-down list.

Rx FIFO trigger levels are available at 1, 4, 8, and 14 bytes, with the default value set at 14 bytes.

6. Check **Set the change to all ports** checkbox if you would like to apply this Rx FIFO Trigger to all of your ports.
7. Select a Tx FIFO Size from the **Tx FIFO Size** pull-down list.

Tx FIFO sizes are available from 1 to 16 bytes, with the default value set at 16 bytes.

8. Check **Set the change to all ports** checkbox if you would like to apply this Tx FIFO Size to all of your ports.

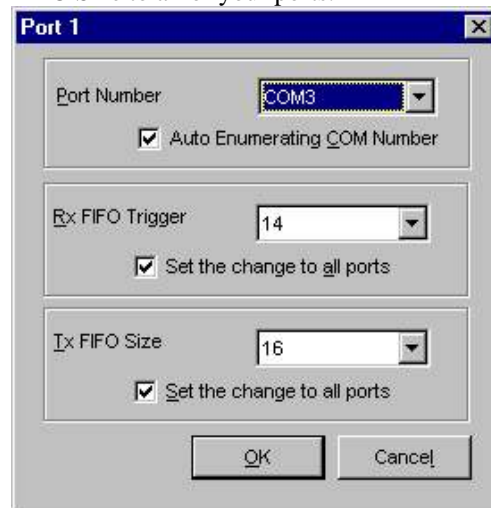

9. Click **OK** in the **Port X** dialog box to confirm the port settings.
10. Click **OK** in the **Property** dialog box to complete the port settings.

Board and Port Ready Stage

There is a slight difference between the **Board and Port Ready Stage** for Windows 95 and Windows 98.

In this stage, we complete the driver installation.

Windows 95

After configuring the ports, you can immediately use the Smartio C168H/PCI board COM ports without restarting Windows 95.

Windows 98

After configuring the ports, click on **Finish**. The Smartio C168H/PCI board COM ports can be used without restarting Windows 98.



Note!

If an error message similar to “**C168 PCI (BusNo=x, DevNo=x, Port1=COMx) interrupt number is invalid!**” pops up, refer to the *Troubleshooting* chapter for help.

If you want to add more boards after installing the driver, simply plug in the additional Smartio C168H/PCI boards and they will be automatically detected by Windows 95/98. In this case, skip to **Port Configuration stage** to take care of the port settings.

At this point, the Smartio C168H/PCI board driver installation should be complete, including configuration of the board and ports. Please refer to the next section, *Configuring Board and Port*, if you need to make any changes to the configuration.

You may start developing applications with *PComm* library (See *Serial Programming Tools*) or Microsoft Win32 API, as soon as the board and driver have been successfully installed and restarted. You can also execute any ready-made applications, such as the *PComm* utility Terminal Emulator (See *Serial Programming*

Tools) or HyperTerminal to transmit/receive data, as well as Remote Access Service to provide dial-up networking capabilities.

Configuring Board and Port

Follow the procedure listed below to re-configure port COM numbers for installed boards and drivers running under Windows 95/98.

Instead of following the procedures listed below, you may also click on Start → Program Files → Moxa Utility → Moxa Smartio/Industio Configuration Panel → Property → Port Setting.

Since this is a PCI board, the system will automatically add or remove the board's configuration once the board has been added or unplugged. This saves you the effort of adding or removing the configuration manually.

1. Open the **Control Panel**, click on the **System** icon, select the **Device Manager** tab, and then choose **Moxa Smartio/Industio multiport board**.
2. Click on the desired C168H/PCI board entry, and then click on **Properties**.

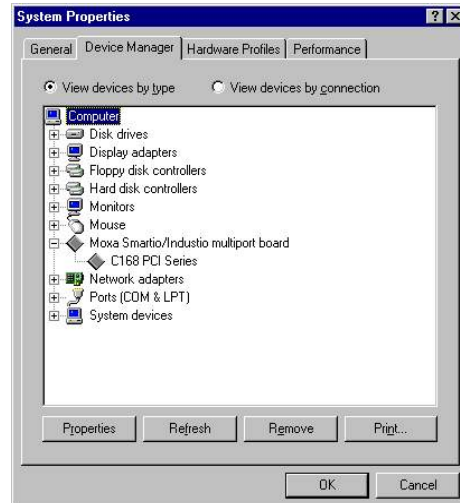

3. Select the **Ports Configuration** tab.
4. Click on a port, and then click on **Port Setting** to re-assign the COM number for the Smartio C168H/PCI port mapping.

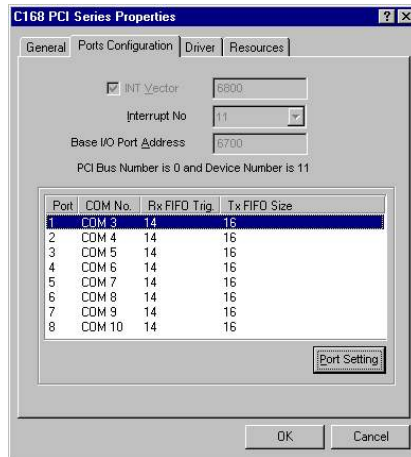

Note! Skip Step 5 if you would like to manually assign COM numbers to the ports.

5. Check the **Auto Enumerating COM Name** checkbox to assign consecutive COM numbers for subsequent ports. For example, if COM 3 is assigned to Port 1, then COM 4 will be automatically assigned to Port 2.

Note! Skip Steps 6 and 7 if the system does not require special performance tuning.

6. Re-assign the Rx FIFO Trigger by selecting a number from the pull-down list. Check the **Set the change to all ports** checkbox if you would like to apply this setting to all ports.

The available Rx FIFO trigger levels are 1, 4, 8, and 14 bytes, with the default value set at 14 bytes.

7. Re-assign the Tx FIFO Size by selecting a number from the pull-down list. Make sure the **Set the change to all ports** checkbox is checked if you would like to apply this setting to all ports.

Tx FIFO sizes are available from 1 to 16 bytes, with the default value set at 16 bytes.

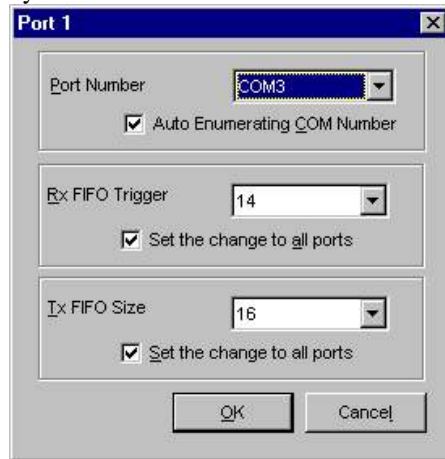

8. Click **OK** in the **Port X** dialog box.
9. Click **OK** in the **C168 PCI Series Properties** dialog box.
10. Click **OK** in the **Device Manager** tab.
11. Restart the system to activate the new configuration.

Updating the Driver

In this section, we discuss how to update the Windows 95/98 driver to enhance the function of the board.

1. Open the **Control Panel**, click on **System**, and then select the **Device Manager** tab.
2. Click on **Moxa C168 PCI Series** and then click on **Properties**.

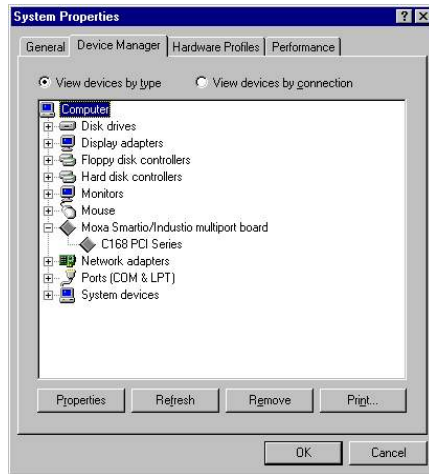

3. Select the **Driver** tab.
4. Click on **Update Driver...**

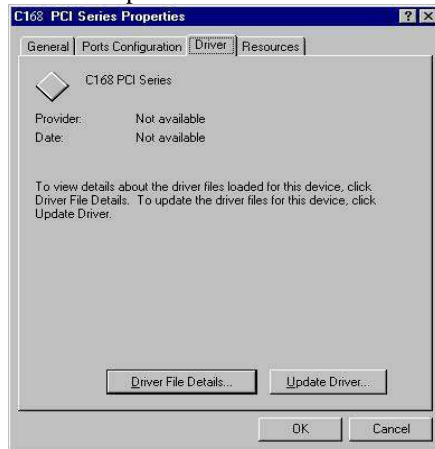

5. Click on **Have Disk...** and then type the path of the new driver.
6. Insert the source diskette into the floppy drive (if there is one).
7. Click **OK** in the **Install from Disk** dialog box.
8. You will be prompted to restart the system. Click on **Yes** to restart, or **No** if you would like to wait and reboot the system later.

Removing the driver

This section explains how to remove the Smartio C168H/PCI driver.

1. Open the **Control Panel**, double click on **Add/Remove Programs**, and then select the **Install/Uninstall** tab.
2. Click on the **Moxa Smartio/Industio Driver** option and then click on **Add/Remove** to start removing the driver.

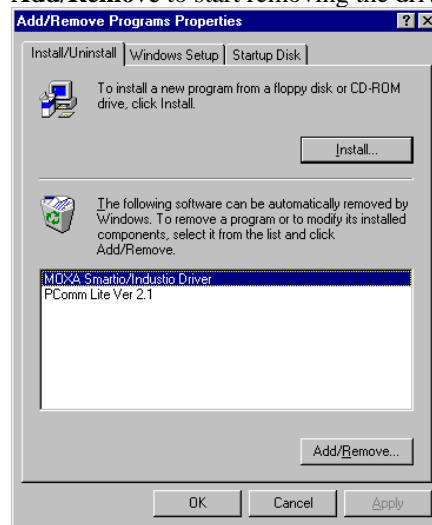

3. Click on **Yes** in the following message box to confirm that you really want to remove the driver.

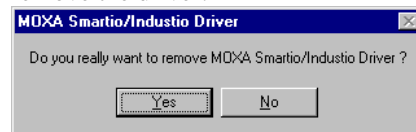

4. Click **OK** in the **Add/Remove Programs Properties** dialog box.

4

Serial Programming Tools

Moxa supports several easy, but powerful, serial programming libraries and communication troubleshooting utilities that run under Windows NT and Windows 95/98. Using Moxa Serial Programming Tools can save you a substantial amount of developing time.

The following sections give details about the installation, the library, and the utilities, for various OS platforms.

PComm, the professional PC serial comm tool, is a software package for **Windows NT** and **Windows 95/98** that consists of:

- A powerful serial communication library for easy programming in the most popular programming languages. The serial communication library is useful for developing data communication applications for remote access, data acquisition, and industrial control in a Windows NT or Windows 95/98 environment. It is also an easier solution compared to the more complex Windows Win32 COMM API.
- Useful utilities such as Diagnostic, Monitor, and Terminal Emulator.
- Illustrative sample programs.
- Comprehensive on-line documentation.

PComm Installation

To install *PComm*, run **Setup.exe** from the diskette included with the board. Note that the *PComm* diagnostic and monitor utilities are for Moxa boards only; therefore, these two utilities will not work on other brands of serial board.

Once *PComm* has been successfully installed, click on **Start**, and select **Program**

Files and the *PComm Lite* group to bring up a list of utilities and documents.

PComm Programming Library

The serial communication library assists you in developing serial communication programs **for any COM port** that complies with Microsoft Win32 API. It facilitates the implementation of multi-process and multi-thread serial communication programs, thus reducing program-developing time by a remarkable amount.

This serial communication library provides a complete library of functions and sample programs for Visual C++, Visual Basic, and Delphi. To view detailed function descriptions and sample programs, click on **Start → Program Files → *PComm Lite* → *PComm Lib Help***, and then ***PComm* Porting Notes** or ***PComm* Programming Guide**. Alternatively, you may also refer to the sample programs located in the *PComm* directory.

Utility

Given below are brief descriptions of each utility. For more information, please see the on-line help located on the diskette.

Diagnostic (for Moxa boards only)

This convenient diagnostic program, which ONLY works for Moxa boards and ports, provides internal and external testing capabilities, including IRQ, TxD/RxD, UART, CTS/RTS, DTR/DSR, and DTR/DCD testing. It can be used to verify that both the software and hardware are functioning correctly.

To run the Diagnostic program, click on **Start**, and then select **Program Files**, **PComm Lite**, and **Diagnostic**.

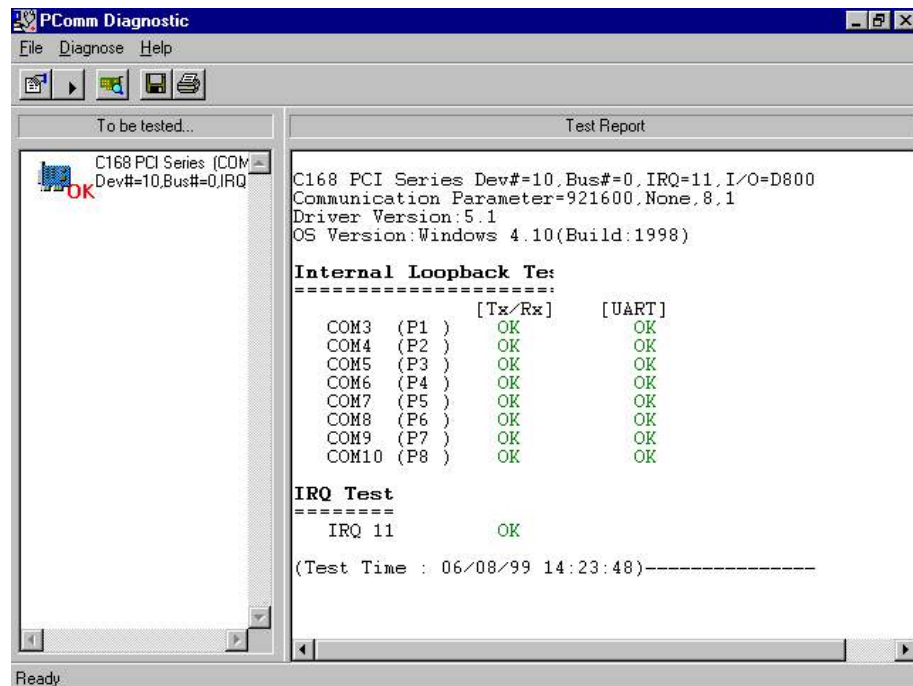

Monitor (for Moxa boards under Windows NT Only)

This useful port status monitoring program allows you to keep an eye on selected Moxa COM ports. It monitors data transmitting/receiving throughput and communication line status, both of which are updated and displayed on the screen at periodic time intervals. By clicking on the specific port being displayed, you can see the current communication parameters and status of that port.

To run the Monitor program, click on **Start**, and then select **Program Files**, **PCComm Lite**, and **Monitor**.

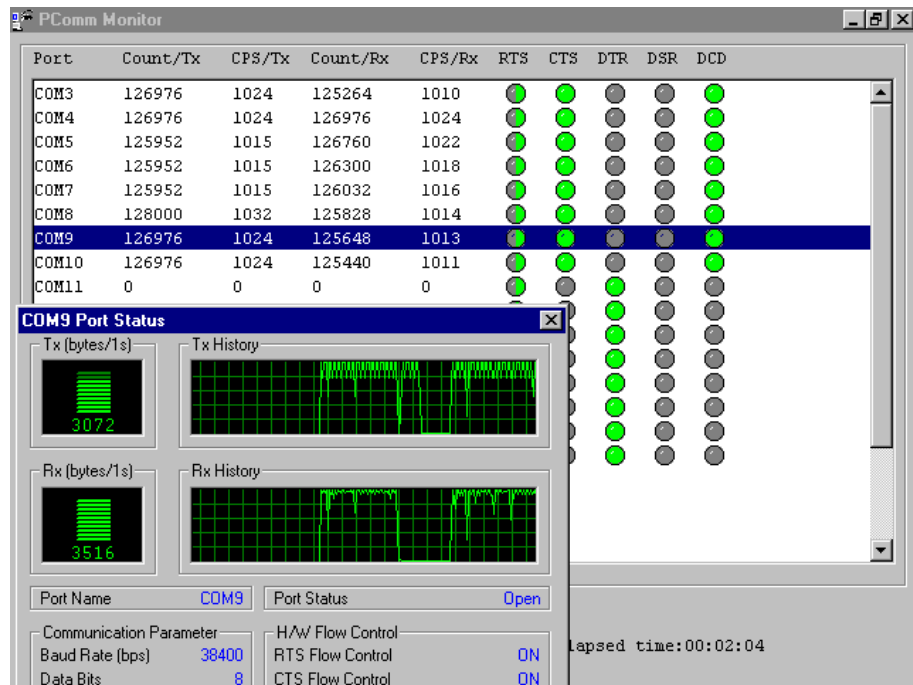

Terminal Emulator

Terminal Emulator is used to simulate various port connections, allowing you to see if signal transmission is functioning correctly. It features multiple-windows, and supports both VT100 and ANSI terminal types, allowing you to transfer data interactively, send patterns periodically, and transfer files using ASCII, XMODEM, YMODEM, ZMODEM, and KERMIT protocols.

To run Terminal Emulator, click on **Start**, and then select **Program Files, PComm Lite, and Terminal Emulator**.

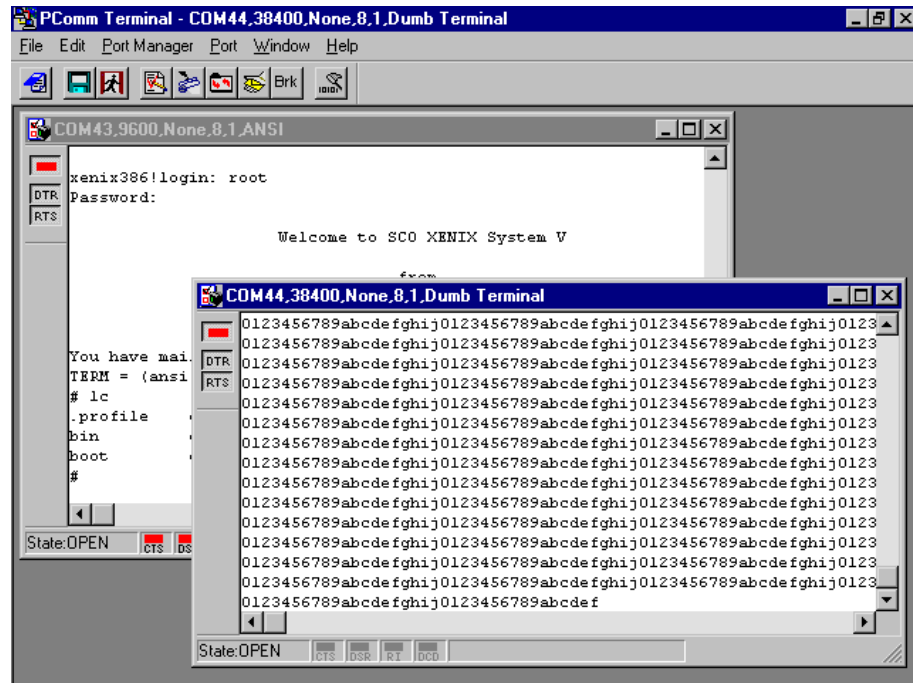

RS-485 Programming for Opt8J

If you intend to use Opt8J for RS-485 communications, follow the RS-485 programming guide given below, and refer to the chapter *Connection Option (Opt8x) and Cable Wiring* for more Opt8J RS-485 operation details.

The Opt8J option only supports **2-wire half-duplex RS-485 communications**. Data +/- pins are used for both data transmitting and receiving, depending on the RTS signal.

The port switch for each port should be set to the **On** position. The port is used for transmitting data if **RTS is asserted** and is used for receiving data if **RTS is not asserted**.

This RTS scheme is suitable for any system that permits RTS control from within application programs. This includes Windows NT, Windows 95/98, DOS, and UNIX.

How to transmit and receive data under Windows NT and Windows 95/98

We recommend that you configure Smartio C168H/PCI ports as follows to acquire precise timing control when using RS-485 2-wire transmission.

There are 2 ways to control RS-485 2-wire transmission.

Solution 1

The following model is commonly used for RS-485 2-wire transmission.

```
sio_SetWriteTimeouts(port, 0);    /* Set sio_write() into block mode */
sio_RTS(port, 1);                /* Turn on RTS signal. The RS-485 port is ready for
                                transmitting data. */
sio_write(port, buff, 10);       /* Write 10 byte characters in "buff". The function
                                blocks until last character transmitted */
sio_RTS(port, 0);                /* Turn off RTS signal. The RS-485 port is ready for
                                receiving data. */
sio_read(port, buff, 10);        /* Read 10 bytes */
```

Solution 2

The *PComm* library contains a dedicated RS-485 function that integrates the functions given in solution 1 regarding sending data.

```
sio_putb_x(port, buff, tick ); /*
```

1. Turn on RTS; ready for transmitting data.
2. Send data.
3. Wait for tick time.
4. Turn off RTS; ready for receiving data. */

For more information about these functions, refer to the *PComm* library on-line Help file for Windows NT and Windows 95/98.

Connection Option (Opt8x) & Cable Wiring

In serial data communications, the term **DTE** stands for Data Terminal Equipment, such as a terminal or PC COM1/2, and the term **DCE** stands for Data Communication Equipment, such as a modem. The precise pinouts and cable wiring schemes are as follows.

RS-232 Cable Wiring for Opt8A/B/C/D/S

The RS-232 8-port connection boxes and octopus cables designed for Smartio C168H/PCI are:

Opt8A: 8-port RS-232 DB25 female connection box

Opt8B: 8-port RS-232 DB25 male connection box

Opt8C: Octopus cable with 8 male RS-232 DB25 ports

Opt8D: Octopus cable with 8 male RS-232 DB9 ports

Opt8S: 8-port RS-232 DB25 surge protected female connection box

Shown below are the pin assignments for various connection options:

Opt8A/S
(DCE, DB25 Female)

- 2 RxD
- 3 TxD
- 4 CTS
- 5 RTS
- 6 DTR
- 7 GND
- 8 DCD
- 20 DSR

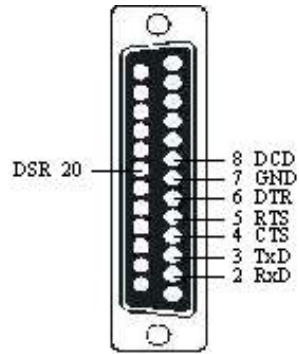

Opt8B/C
(DTE, DB25 Male)

- 2 TxD
- 3 RxD
- 4 RTS
- 5 CTS
- 6 DSR
- 7 GND
- 8 DCD
- 20 DTR

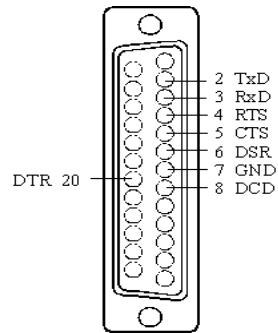

Opt8D
(DTE, DB9 Male)

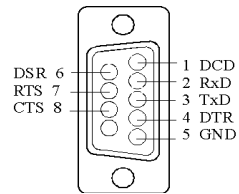

Connection Option (Opt8x) and Cable Wiring

- 1 DCD
- 2 RxD
- 3 TxD
- 4 DTR
- 5 GND
- 6 DSR
- 7 RTS
- 8 CTS

Type 1: To connect Smartio C168H/PCI to a DTE device.

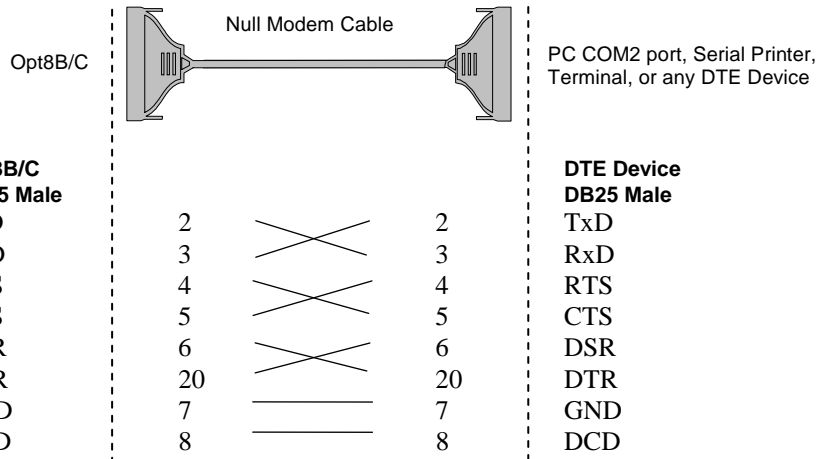
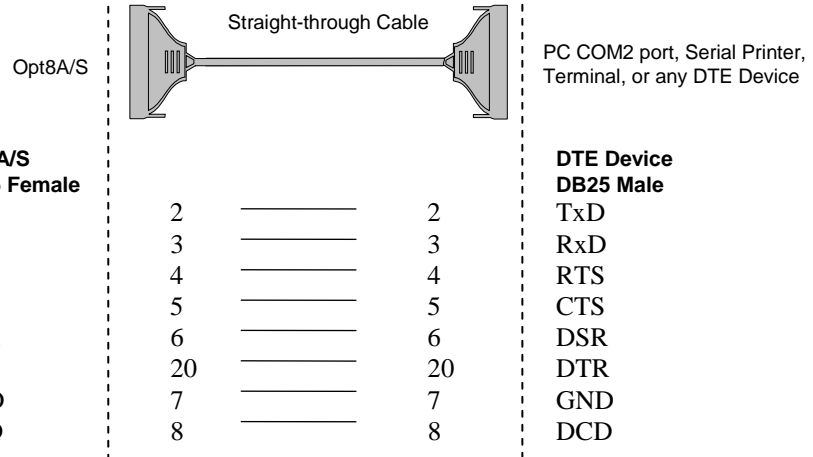

Connection Option (Opt8x) and Cable Wiring

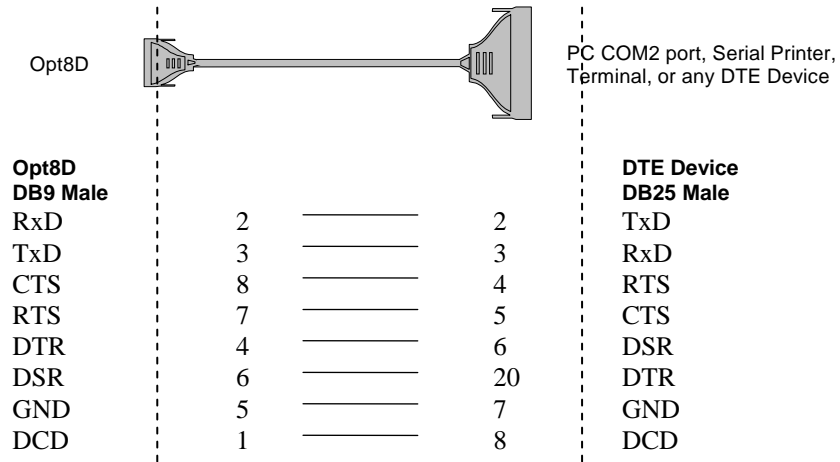

Type 2: To connect Smartio C168H/PCI to a DCE device.

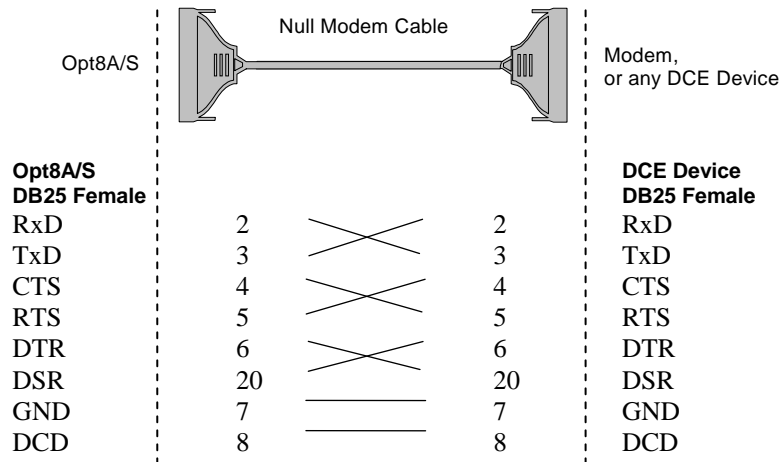

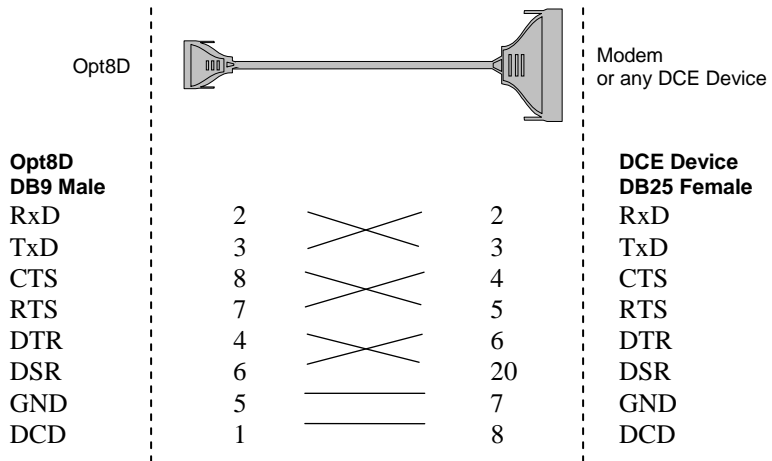
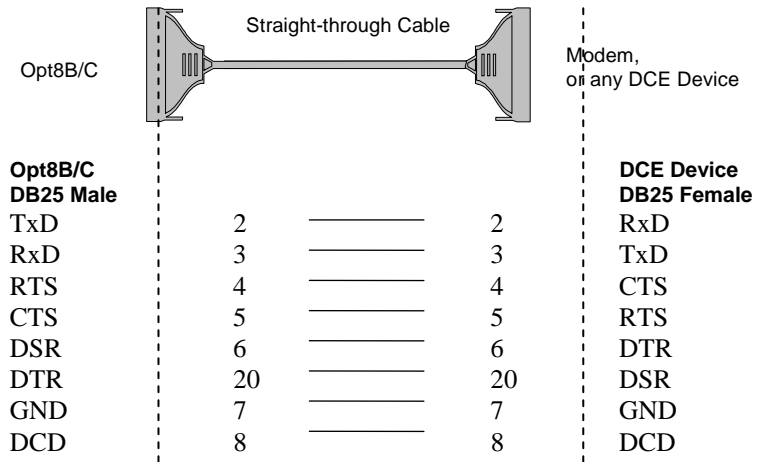

Type 3: To connect Smartio C168H/PCI to a DTE with 3-pin wiring.

If the **Hardware flow control** feature is set to **ON**, you must loop back (or short) RTS with CTS, and DSR with DTR, DCD on the Moxa side, indicated with dash-lines in the following diagrams. If the **Hardware flow control** feature is set to **OFF**, you can just leave RTS, CTS, DSR, DTR, DCD open, ignoring the connections indicated with dashed lines.

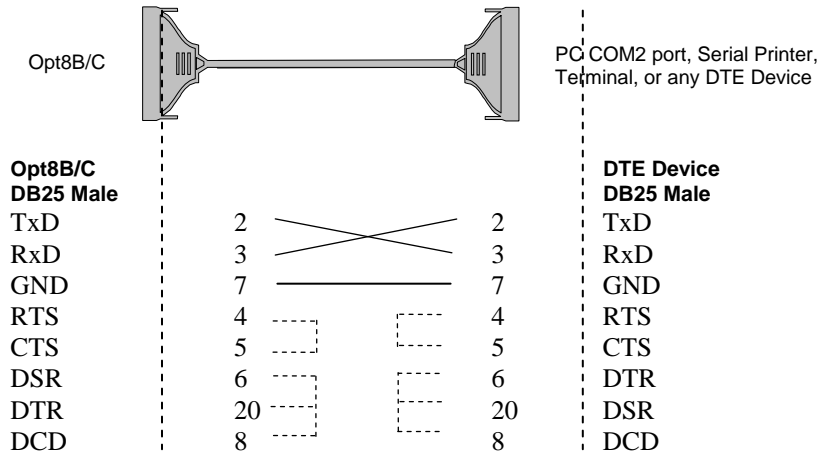
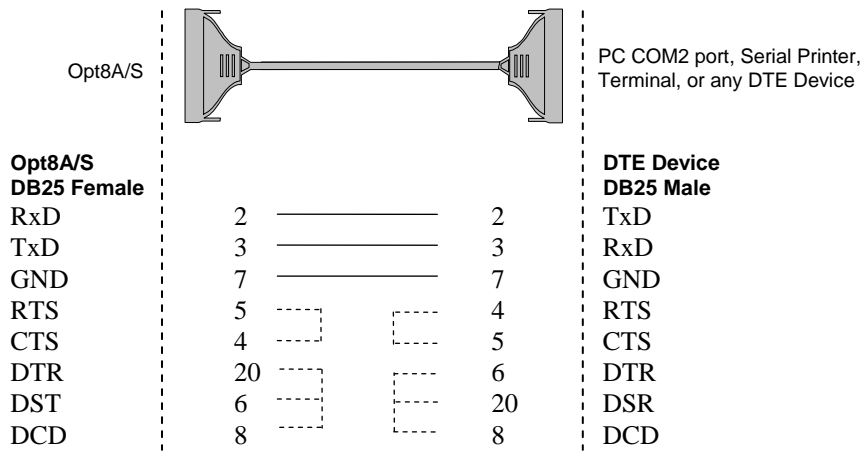

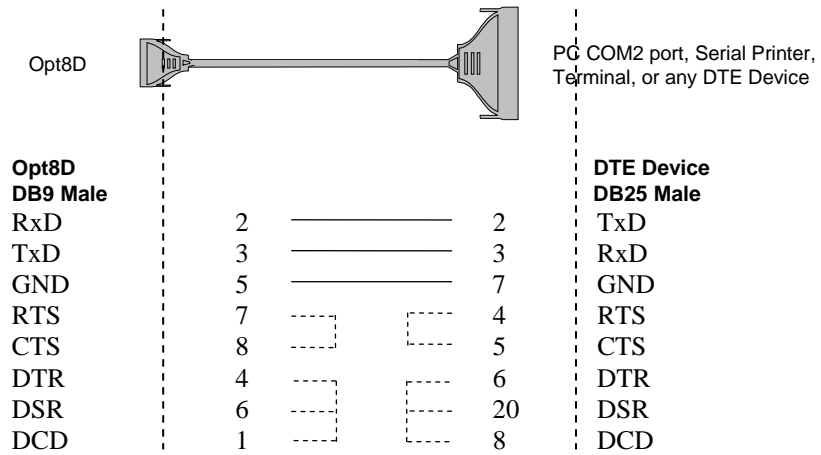

RS-422 Cable Wiring for Opt8J/F/Z

RS-422 connection boxes designed for Smartio C168H/PCI boards are:

Opt8J: Connection box with 8 female RS-422/485 DB25 ports. Set the port switch to the **OFF** position (RS-422) for the desired port(s).

Opt8F: Connection box with 8 female RS-422 DB25 ports and a maximum of 500V DC isolation protection, helping to prevent damage caused by high potential voltage.

Opt8Z: Connection box with 8 female RS-422 DB25 ports, but without isolation protection.

RS-422 Pinouts for Opt8J/F/Z: pt8J/F/Z

2	RxD+(B)	} Opt8J only
3	TxD+(B)	
14	RxD-(A)	
16	TxD-(A)	
7	GND	
4	CTS+(B)	
5	RTS+(B)	
13	RTS-(A)	
19	CTS-(A)	

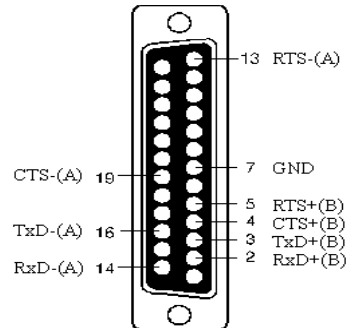

The RS-422 transmission distance can be as much as 4000 ft, and consequently the connection box needs an external power adapter to supply 5V DC power. Either a 110V or 220V AC power adapter can be used with this product, depending on your company's power supply.

Given below are the RS-422 operation modes:

RS-422 Point-to-point

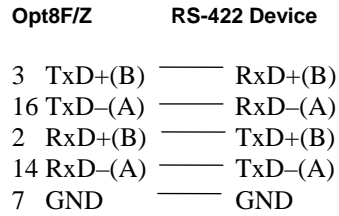

RS-422 Broadcasting

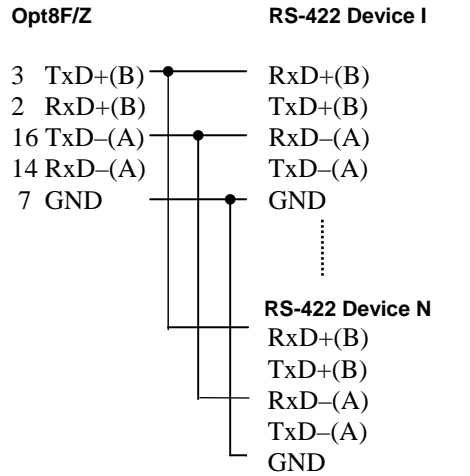

Opt8J RS-422 with Handshaking

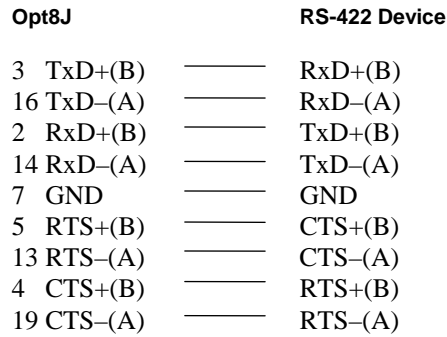

RS-485 Cable Wiring for Opt8J

One of the RS-485 connection boxes designed for Smartio C168H/PCI is:

Opt8J: Connection box with 8 female RS-422/485 DB25 ports. Set the port switch to the **ON** position.

The Opt8J option only supports **2-wire half-duplex RS-485 communication**. Data +/- pins are used for both data transmitting and receiving, depending on the RTS signal.

RS-485 Pinouts for Opt8J:

Opt8J	
3	Data+(B)
7	GND
16	Data-(A)

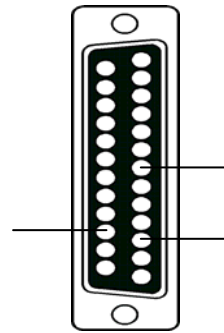

Multidrop RS-485 Half-duplex

Point-to-Point RS-485 Half-duplex

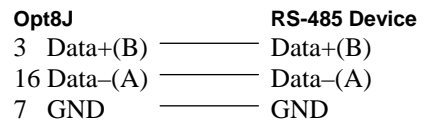
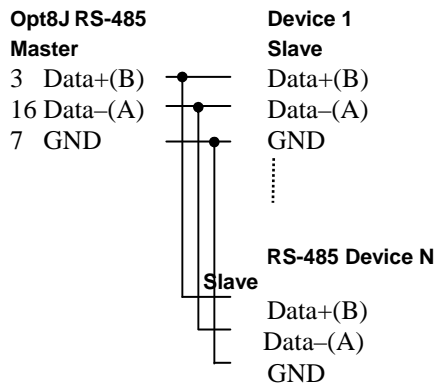

See the section *RS-485 Programming* in the chapter *Serial Programming Tools* for more details on Opt8J RS-485 programming.

RS-422/485 Impedance Matching

When using RS-422/485 serial communications, an electrical signal travels through two different resistance junctions in a transmission line. The impedance mismatch that exists will sometimes cause signal reflection, distorting the signal. This in turn contributes to communication errors. The solution to this problem is to establish the same impedance at the line ends as in the line itself, by terminating them with resistors.

The resistance of the termination resistor should equal the characteristic impedance of the transmission line. Resistors should be added **near the receiving side**.

Opt8J/F/Z		RS-422/485 Device
3	TxD+(B)	RxD+(B)
16	TxD-(A)	RxD-(A)
2	RxD+(B)	TxD+(B)
14	RxD-(A)	TxD-(A)
5	RTS+(B)	CTS+(B)
13	RTS-(A)	CTS-(A)
4	CTS+(B)	RTS+(B)
19	CTS-(A)	RTS-(A)

} **Opt8J only**

Note:

1. ξ represents a termination resistor near the receiving side
2. The suggested termination resistor for AWG #26 cable is 100 ohm.
3. The suggested termination resistor for phone cable is 600 ohm.

6

Troubleshooting

In this chapter, we list several problems that could arise when using Smartio C168H/PCI, and solutions you can follow to fix the problems. If you are unable to find a solution to your particular problem in this chapter, contact either a dealer or Moxa for help. To receive a quicker response from your dealer, please use the **Problem Report Form** at the end of this manual.

General Troubleshooting

1. **While installing the driver, the Moxa driver is unable to detect the Moxa PCI board.**

Hardware causes and solutions:

- A. The board is not installed. Please install it.
 - B. The board is not properly plugged into the system. If this is the case, re-plug the board into a 32-bit PCI slot. It may also be the case that the slot you've chosen could be damaged. In this case, try other slots until you find one that works.
 - C. The motherboard does not have an available IRQ for the C168H/PCI board. In this case, enter the BIOS and make sure an IRQ is available in the PCI/PnP settings.
2. **The Moxa board and driver are activated but cannot transfer data (either transmitting or receiving).**

Hardware Causes and Solutions:

- A. Check to see if the cable is wired correctly. Refer to the *Connection Option (Opt&x) and Cable Wiring* chapter for correct cabling information.

-
- B. Either the cable or board could be defective. Try other ports, cables, and boards to verify this, or use *PComm* Diagnostic utility to test the Moxa board and port conditions. If Diagnostic reports an error, replace the faulty components.

Software Causes and Solutions:

- C. The Smartio C168H/PCI board will check the line status (CTS) before transmitting data if the RTS/CTS flow control feature is set to Enable in either the configuration or application program. Refer to the *Connection Option (Opt&x) and Cable Wiring* chapter for proper wiring specs, and check the line status of the suspected port using the diagnostic LED indicators on the mini tester.
- D. The board controlling application might not be written correctly for the corresponding API of the operating system. To see if this is the case, run another application that you know is good, or use utilities provided by Moxa. You can either use *PComm* Terminal emulator or HyperTerminal under Windows NT and Windows 95/98.

Windows NT

This section is specifically for troubleshooting under Windows NT. For general problems and solutions, see the previous section, General Troubleshooting.

1. **After the system reboots, the error message “Another driver in the system, which did not report its resources, has already claimed the interrupt used by xxx.” appears in the Event Log.**

This indicates that the Moxa board was found, but the IRQ that was assigned conflicts with another adapter’s IRQ setting. Check the PCI BIOS IRQ settings first, and then select an available IRQ.

2. **After the system reboots, the error message “Cannot find any configured Moxa Smartio/Industio series board!” appears in the Event Log.**

Make sure the PCI board is seated firmly in the expansion slot.

3. **The COM number of the Smartio C168H/PCI (Bus No=x Dev No=x, Port1=COMx), with device number xx, conflicts with others.**

Different boards have conflicting COM numbers. Change the Moxa board's COM number mappings.

4. Windows NT system panic (blue screen).

One possible reason is an IRQ or I/O address conflict with other ISA Bus adapters, such as LAN and SCSI boards, or the system BIOS. Refer to the corresponding problem in the previous *General Troubleshooting* section for solutions.

Windows 95/98

This section is specific for troubleshooting under Windows 95/98. For general problems and solutions, see the previous section, *General Troubleshooting*.

1. The system cannot find the Smartio C168H/PCI board!

- The boards are not properly plugged in.
- The slot being used is defective. Try other slots until you find one that works.
- The board might be defective.

2. After the system reboots, the error message “C168H/PCI (BusNo=x, DevNo=x, Port1=COMx) interrupt number is invalid!” appears.

This indicates that the Moxa board has been found, but the IRQ that was assigned conflicts with another adapter. Make sure the Moxa board's IRQ does not conflict with another adapter's IRQ setting. Check the PCI BIOS IRQ settings and select an available IRQ for the Moxa board.

A

Technical Reference

Specifications

- ❖ Bus interface: 32-bit PCI (PCI Spec. 2.1 compliance)
- ❖ Number of ports: 8
- ❖ Max. No. of boards: 4
- ❖ IRQ: Assigned by PCI BIOS
- ❖ I/O address: Assigned by PCI BIOS
- ❖ Speed (bps): 50 – 921.6 Kbps
- ❖ Data bits: 5, 6, 7, 8
- ❖ Stop bits: 1, 1.5, 2
- ❖ Parity: none, even, odd, space, mark
- ❖ UART: 8 × 16C550C or compatible
- ❖ Data signals: RS-232 – TxD, RxD, RTS, CTS, DTR, DSR, DCD, GND
RS-422 – TxD+/-, RxD+/-, GND (Opt&J: RTS+/-, CTS+/-)
RS-485 – Data+/-, GND
- ❖ Connectors: 8 × DB25/DB9 male/female (DTE/DCE)
- ❖ Operating temp: 0 – 55 °C
- ❖ Power requirement: 180 mA (+5V), 110 mA (+12V), 160 mA (-12V)
- ❖ Dimensions: 123 × 100 mm
- ❖ Operating Systems: Window NT/95/98 and DOS

PCI

The 32-bit Smartio C168H/PCI board complies with PCI specifications 2.1. Hardware configurations for IRQ and I/O addresses are automatically assigned by the PCI BIOS. Hence, you must **first plug the board in** before installing the driver software.

Unlike ISA slots, different PCI slots in the same PC may have different bus numbers and device numbers with respect to the PCI specifications. The same PCI board will have different system configurations if switched to a different PCI slot. This is

referred to as **slot-sensitive** or **slot-dependent**, and may apply to PCI slots in PCs with different motherboards and **different device number sets**. For example, some use 17, 18, 19, and 20 for identifying the respective PCI slots, but some use 11, 12, 13, and 14.

Due to **slot-dependency**, it is necessary to **re-configure the driver software** once the board is plugged into a different PCI slot.

Up to 4 Smartio C168H/PCI boards can be installed in one system. When installing more than one board, **remember the order of boards** to distinguish the installed boards from each other.

UART 16C550C

The UART 16C550C chip is an intelligent asynchronous controller supporting one full duplex channel that simultaneously transfers data at 921.6 Kbps speed. To increase the overall data throughput, special features such as on-chip FIFO and on-chip hardware flow control are used to reduce the number of interrupts to the onboard CPU and to prevent loss of valuable data.

DB62 Connector Pinouts

Below we list the pin assignments for the **DB62** connector on the bracket.

Pin No.	Signal	Pin No.	Signal	Pin No.	Signal
1	TxD1	22	RxD1	43	CTS1
2	DTR1	23	DSR1	44	RTS1
		24	DCD1	45	GND
3	RxD2	25	TxD2	46	CTS2
4	DSR2	26	DTR2	47	RTS2
5	DCD2				
6	TxD3	27	RxD3	48	CTS3
7	DTR3	28	DSR3	49	RTS3
		29	DCD3	50	GND
8	RxD4	30	TxD4	51	CTS4
9	DSR4	31	DTR4	52	RTS4
10	DCD4	32	GND		
11	RxD5	33	TxD5	53	CTS5
12	DSR5	34	DTR5	54	RTS5
13	DCD5			55	GND
14	TxD6	35	RxD6	56	CTS6
15	DTR6	36	DSR6	57	RTS6
		37	DCD6	58	GND
16	RxD7	38	TxD7	59	CTS7
17	DSR7	39	DTR7	60	RTS7
18	DCD7	40	GND		
19	RxD8	41	TxD8	61	CTS8
20	DSR8	42	DTR8	62	RTS8
21	DCD8				

Problem Report Form

Smartio C168H/PCI

Customer name:	
Company:	
Tel:	Fax:
E-mail:	Date:

1. **Moxa Product:** C168H/PCI Serial Number: _____
2. **Moxa Driver version:** _____
3. **Moxa hardware settings:** PCI Slot number _____
4. **Operating System:** DOS Windows 95/98
 Windows NT 3.51 Windows NT 4.0
 Others
5. **PC Host:** Make _____ Model _____
6. **CPU:** Speed _____ MHz Make _____ Model _____
7. **BIOS:** Make _____ Version _____
8. **PCI IRQ Configuration in BIOS:**

Slot no.	1	2	3	4
IRQ no				

9. **Problem Description:** Please describe the symptom as clearly as possible, including any error messages. We may need to follow your description in order to reproduce the symptom.

- Board not found. Board found, but cannot transfer data.
 Can transfer data, but data lost Can transfer data, but data is garbled.
 Others: Please give a detailed error message description:

Return Procedure

For product repair, exchange, or refund, the customer must:

- ❖ Provide evidence of original purchase
- ❖ Obtain a Product Return Agreement (PRA) from the sales representative or dealer
- ❖ Fill out the Problem Report Form (PRF), including as much detail as possible for a shorter product repair time.
- ❖ Carefully pack the product in an anti-static package, and send it, pre-paid, to the dealer. The PRA should show on the outside of the package, and include a description of the problem, along with the return address and telephone number of a technical contact.